

DIRT & GRAVEL ROAD
n.t.s.

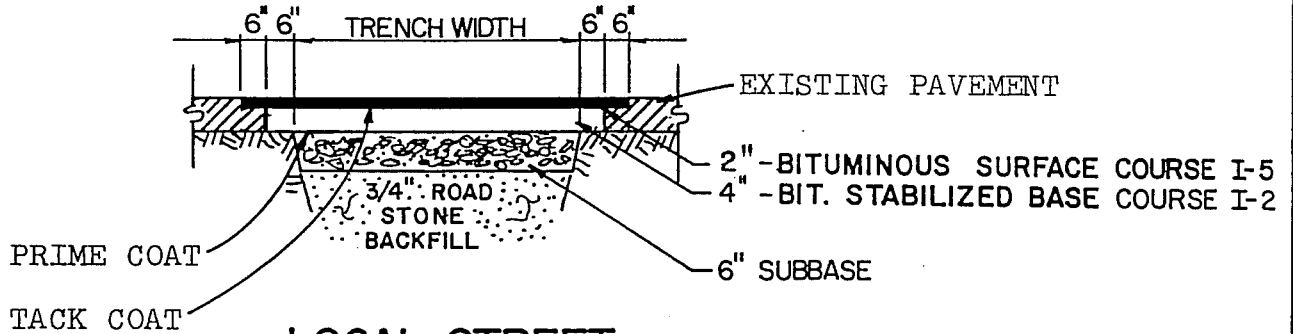

LOCAL STREET
n.t.s.

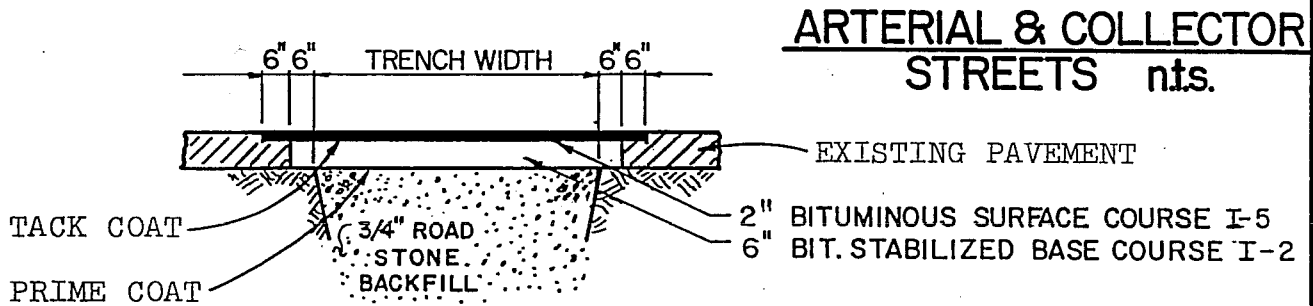

ARTERIAL & COLLECTOR
STREETS n.t.s.

NOTES:

EXISTING PAVEMENT TO BE SAW CUT IN STRAIGHT LINE PARALLEL TO TRENCH ALIGNMENT.

PAY LIMITS MAY BE EXTENDED WHEN SUB-SURFACE CONDITIONS WARRANT AS DETERMINED BY THE TOWNSHIP ENGINEER.

EDGES OF PAVEMENT TO BE SEALED WITH RUBBER ASPHALT JOINT SEALER.

HILLSBOROUGH TOWNSHIP
ENGINEERING STANDARD

EXISTING PAVEMENT REPLACEMENT

REVISED OCT. 1985

C.H. KURK
TWP. ENG'R.

NOMINAL PAVEMENT WIDTH

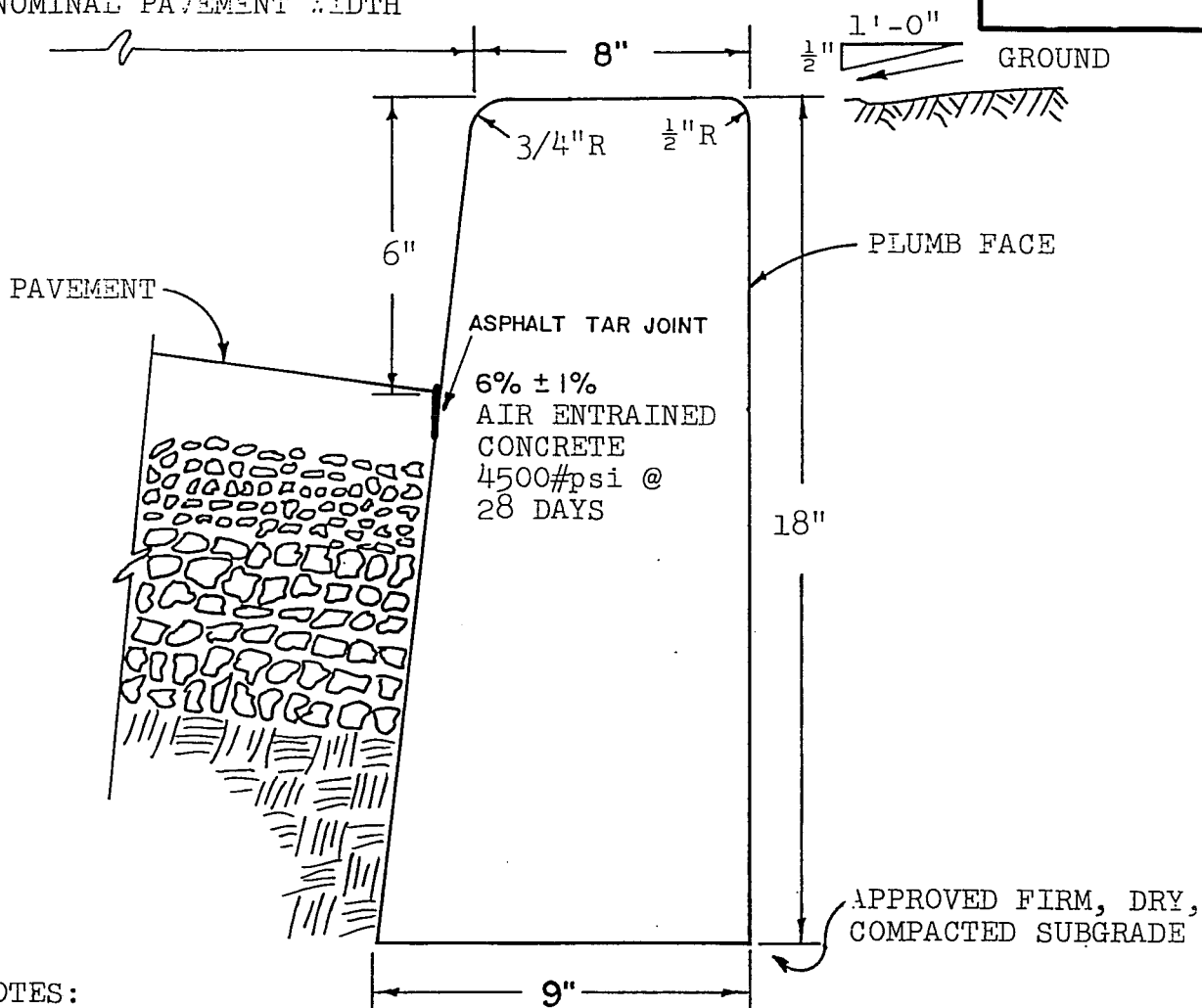
**NOTES:**

1. PROVIDE $\frac{1}{2}$ " EXPANSION JOINTS AT 20'-0" C.C. MAXIMUM WITH $\frac{1}{4}$ " RADIUS @ JOINT EDGES AND CONTRACTION JOINT PLATES AT 10' O.C..
2. EXPANSION JOINT MATERIAL TO BE BLACK FIBER IMPREGNATED, CELLULAR TYPE JOINT FILLER, STRAIGHT AND PLUMB, AND $\frac{1}{2}$ " THICK MINIMUM - AASHTO-M153 TYPE III INSET $\frac{1}{4}$ " FROM FACE AND TOP.
3. PROVIDE EXPANSION JOINTS BETWEEN CURB AND ADJACENT CONCRETE PAVEMENT, SIDEWALK AND/OR DRIVEWAY APRONS AT 10' SECTIONS.
4. HOT-POURED RUBBER ASPHALT JOINT SEALER SHALL BE APPLIED TO PAVEMENT/CURB JOINT AS DIRECTED.
5. TOP AND FACE TO RECEIVE WOOD FLOAT FINISH TO AN EVEN, SMOOTH DENSE SURFACE.
6. CONCRETE SHALL BE CURED BY THE PROCEDURES SPECIFIED HEREIN.
7. EXPOSED CURB FACE MAY BE REDUCED TO 4" MINIMUM WHERE NEEDED TO MEET EXISTING CONDITIONS.

HILLSBOROUGH TOWNSHIP
ENGINEERING STANDARD

STANDARD 8"X18" CONCRETE
CURB

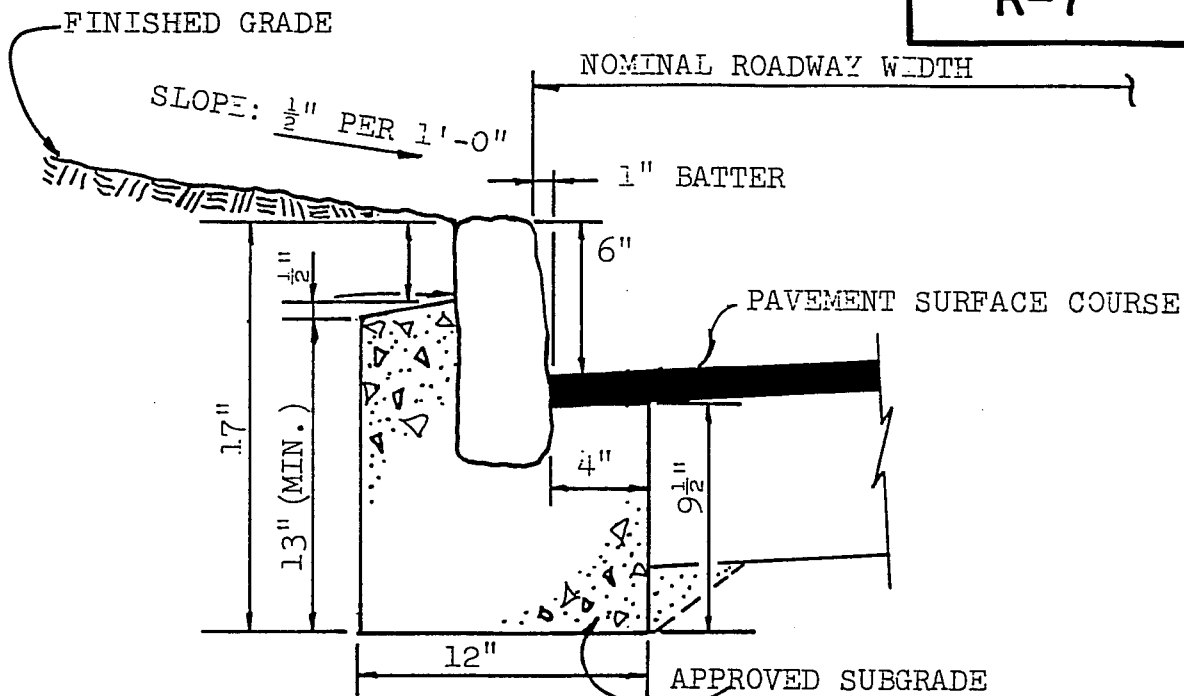

JOINTS TO BE 3/4" WIDE MAX. & POINTED WITH NON-SHRINK CEMENT MORTAR.

FINISHED PAVEMENT SURFACE

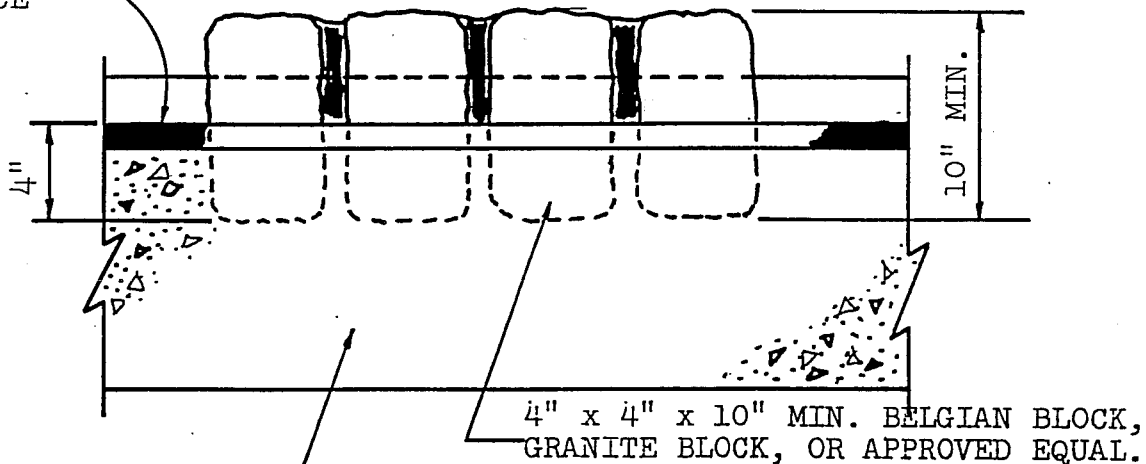

4500 psi CONCRETE @ 28 DAYS WITH 6% ± 1% AIR ENTRAINMENT

NOTES:

1. CONSTRUCTION AT DRIVEWAY APRONS SIMILAR TO DETAIL R-9. JOINTS TO BE CLEANED AND DAMP PRIOR TO POINTING.
2. EXPOSED CURB FACE MAY BE REDUCED TO 4" MINIMUM WHERE NEEDED TO MEET EXISTING CONDITIONS.

HILLSBOROUGH TOWNSHIP
ENGINEERING STANDARD

BELGIAN BLOCK CURB

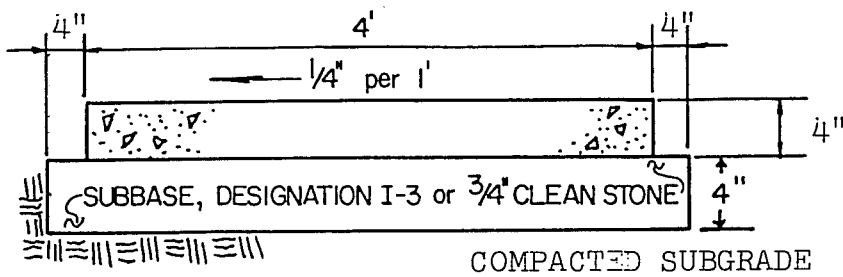

- 4500 PSI CONCRETE @ 28 DAYS WITH 6% ±1% AIR ENTRAINMENT

TYPICAL SIDEWALK

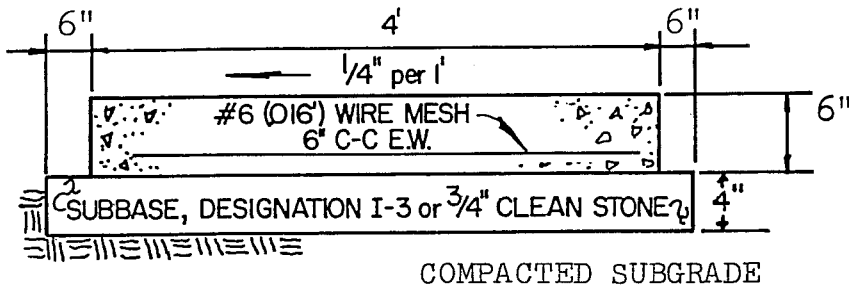

- REINFORCED 4500 PSI CONCRETE @ 28 DAYS WITH 6% ±1% AIR ENTRAINMENT

SIDEWALK AT DRIVEWAYS

GENERAL NOTES:

1. CONCRETE TO BE PLACED AND CURED IN ACCORDANCE WITH THE PROCEDURES SPECIFIED HEREIN.
2. BASE COURSE MAY BE OMITTED IF SUBGRADE MATERIAL IS SATISFACTORY TO THE TOWNSHIP ENGINEER.
3. DRIVEWAY APRON TO CONFORM WITH REQUIREMENTS FOR SIDEWALK AT DRIVEWAYS AND DIMENSIONS PER DETAIL R-8.
4. ALTERNATE EXPANSION JOINTS AND CONSTRUCTION JOINTS TO BE PLACED EVERY 8'.
5. ALONG ALL ROADWAYS SIDEWALK SHALL BE CONSTRUCTED 2' FROM PROPERTY LINE UNLESS OTHERWISE DIRECTED BY THE ENGINEER.

HILLSBOROUGH TOWNSHIP
ENGINEERING STANDARD

CONCRETE SIDEWALK

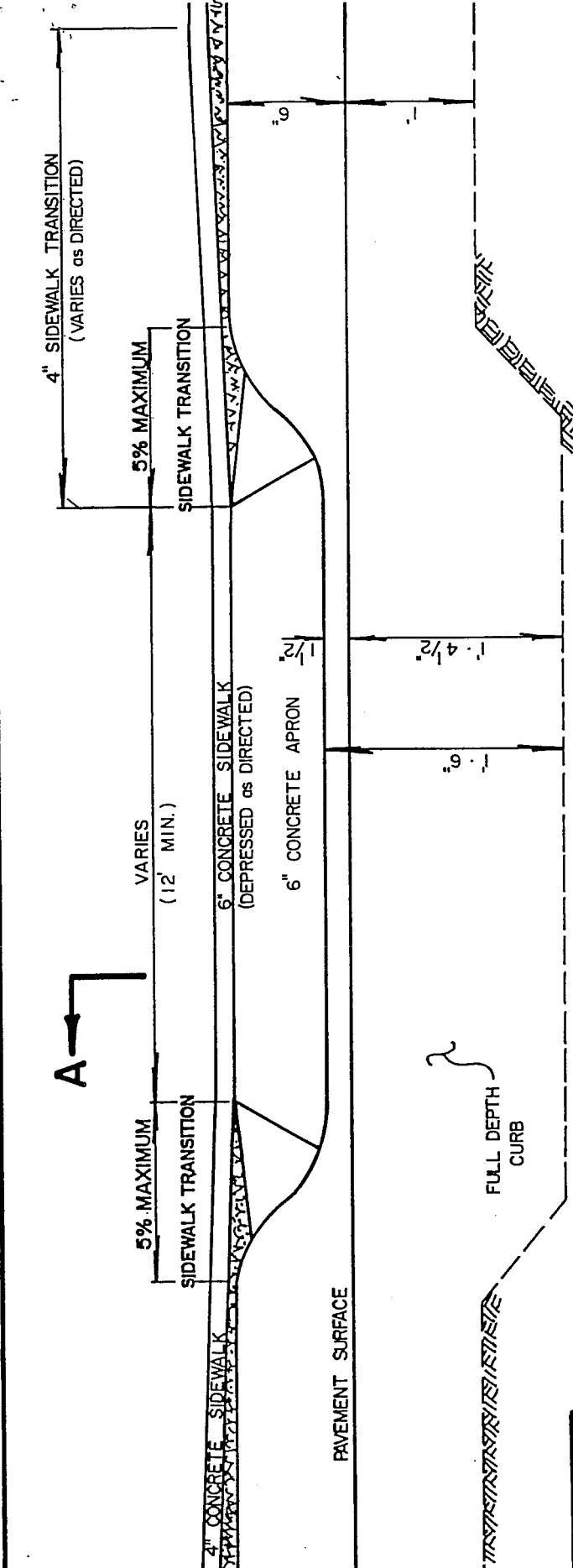

ELEVATION
n.t.s.

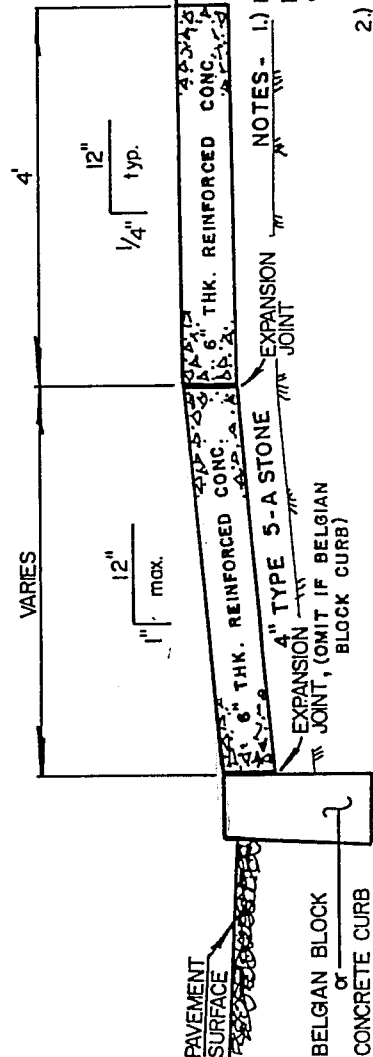

+8% to -4% : PREFERRED GRADES FIRST 16'
+14% to -8% : MAXIMUM GRADES FIRST 16'

NOTES - 1.) IN RURAL AREAS WHERE SIDEWALK IS NOT PRESENT, DRIVE APRON WILL EXTEND TO PROPERTY LINE.

2.) 6" REINFORCED APRON MAY BE SUBSTITUTED BY 6" STABILIZED BASE I-2 APPLIED IN (2) 3" LIFTS.

SECTION A - A
n.t.s.

HILLSBOROUGH TOWNSHIP
ENGINEERING STANDARD
CURB AND APRON AT DRIVEWAYS

I.	RURAL DRIVE NOTES		2/4/83
	REVISION	AUTH.	DATE

BITUMINOUS DRIVEWAY

R-13

DRIVEWAY SLOPE - MAX 15% GRADE ALLOWED WHEN 8% GRADE IS PROVIDED ADJACENT TO GARAGE. W/O THE 8%, THE MAX. ALLOWED IS 12%.

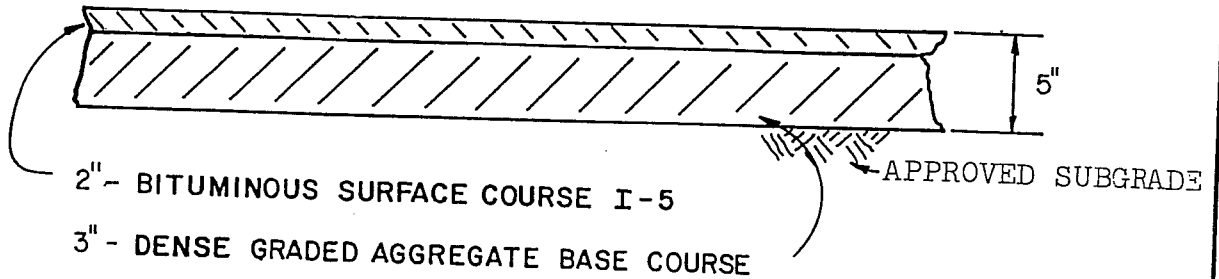

CONCRETE DRIVEWAY

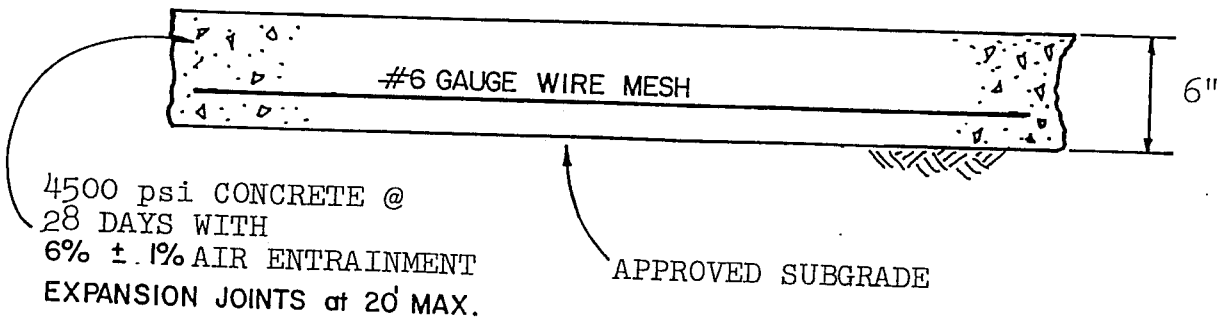

DIRT & STONE DRIVEWAY

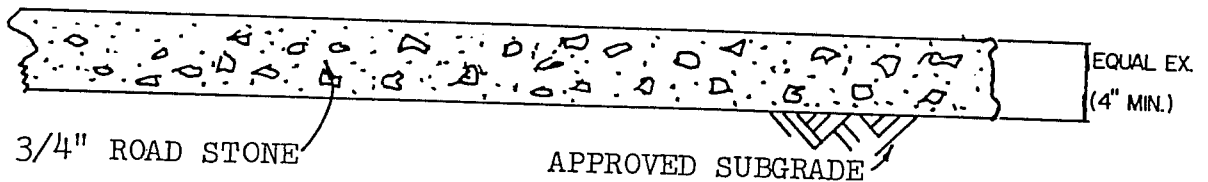

NOTE

THICKNESS REQUIREMENTS MAY BE REVISED AS DIRECTED BY THE TOWNSHIP ENGINEER.

HILLSBOROUGH TOWNSHIP
ENGINEERING STANDARD
DRIVEWAY PAVEMENT
CONSTRUCTION

C.H.KURK
TWP. ENGR

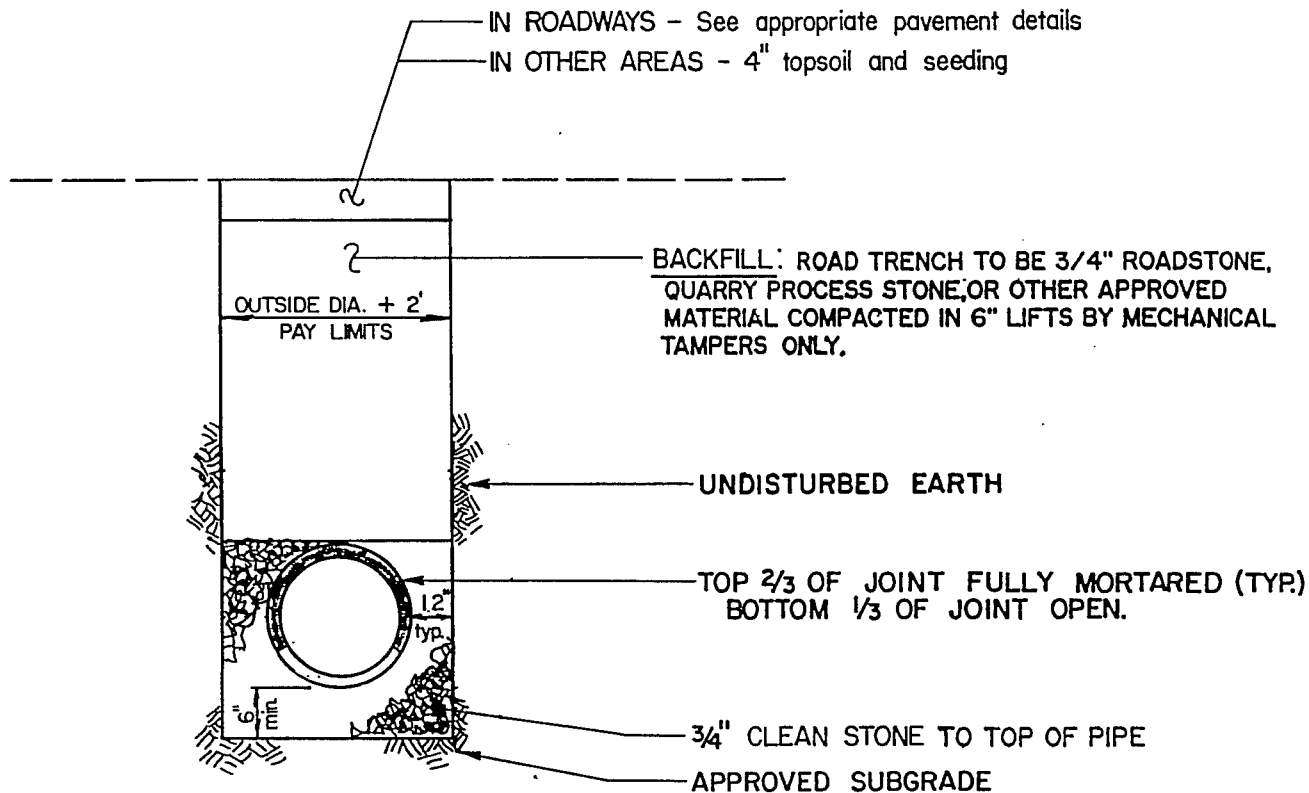

PAY LIMITS MAY BE EXTENDED AS DETERMINED BY THE ENGINEER.

TEMPORARY SHEETING AND SHORING MUST BE PROVIDED IN COMPLIANCE WITH O.S.H.A.

- TAMPING SPEC'S:**
- 3/4" Clean compacted at top.
 - Blend or Bankrun Tamped in 8" Lifts
 - Approved select on site material to be tamped in 6" lifts.

HILLSBOROUGH TOWNSHIP
 ENGINEERING STANDARD

TYPICAL STORM DRAIN TRENCH

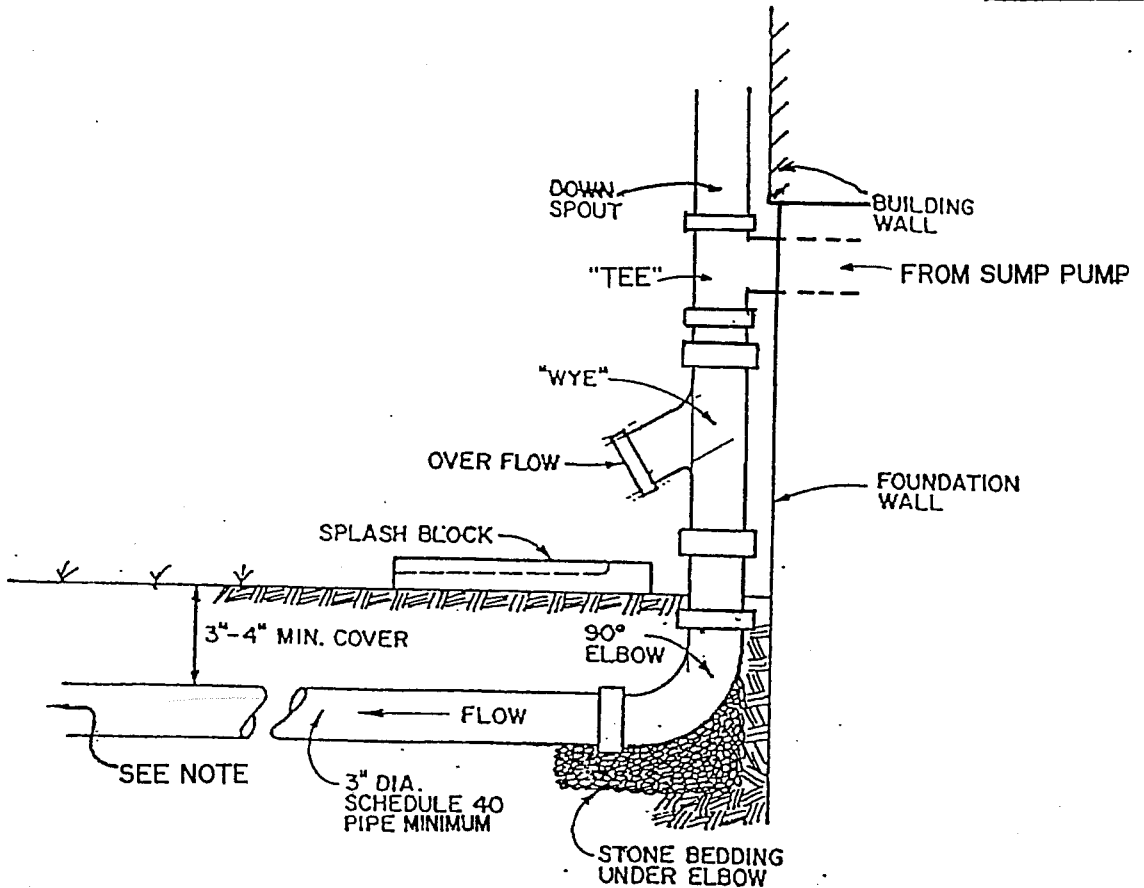

SUMP PUMPS AND ROOF LEADERS TO BE TIED INTO STORM DRAINAGE SYSTEM (NEAREST INLET). LEADERS ONLY MAY DISCHARGE TO ROADWAY GUTTER IF STORM DRAINAGE SYSTEM IS NOT ADJOINING THE PROPERTY.

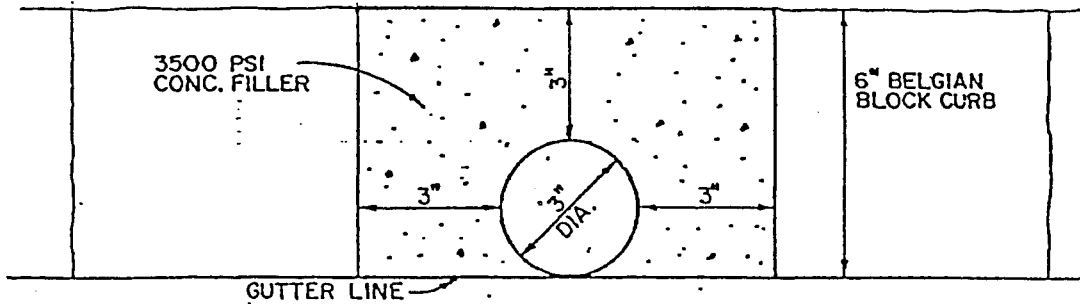

HILLSBOROUGH TOWNSHIP
ENGINEERING STANDARD

SUMP PUMP / ROOF LEADER
TIE-IN